

Daytek®



Rotary Fold Away Clothesline

Suitable for Daytek Rotary Clotheslines
Model 32 / 42 / 52

Please check the carton contains all required parts before assembly.

Your carton should contain the following Daytek Rotary Clothesline parts:

1. **Main Tube Assembly** including gear box and ground socket assembly.
2. **Hoist Tube Assembly** complete with 4 arm assemblies and pre-strung lines.
(Please Note: Do not remove rubber bands, lines are retained to each arm with rubber bands to prevent tangling)
3. **Ground Socket Cap** (Used to seal the ground socket when clothesline is removed from ground)

Materials required for preparing fold away clothesline foundations:

- One 10 litre bucket of medium aggregate screenings
- Two 20kg bags of pre-mix concrete
- Three wooden stakes 25mm x 50mm x 400mm
- 3 lengths of medium cord each 2 metres long
- 1 spirit level (approx 500mm long)

Preparing the site for your Rotary Clothesline

1. Ensure the position selected for hoist foundations has 3.5m clearance on all sides from the central location. This will prevent longer items (sheets etc) from becoming soiled.
2. Excavate a hole 250mm in diameter x 600mm deep.
3. Backfill the hole with screenings 450mm from ground level. This is necessary to drain rain water that enters via the socket.
4. Position the main tube assembly (as packed complete with ground socket) so that it sits centrally and vertically in the hole. The bottom end of the ground socket will rest on the screening while the top of the ground socket should reach ground level.
5. To retain the ground socket in a central position backfill screenings to 425mm from ground level. Ensure no screenings or concrete are in the socket.
6. Position 3 stakes spaced at an equal distance around the hole approximately 1 metre out. Angle the stakes 300mm into the ground.
7. Tie a length of cord from each stake to the main tube assembly to secure vertically. Check the main tube assembly is vertical in two directions using the spirit level.
8. Prepare the pre-mix concrete to a wet, damp mix.
9. Backfill the hole with concrete mix and gently compact the concrete.
10. Ensure the concrete is underneath the top lip of the ground socket.
11. Leave for 24 hours to set concrete before assembling the hoist tube assembly with arms

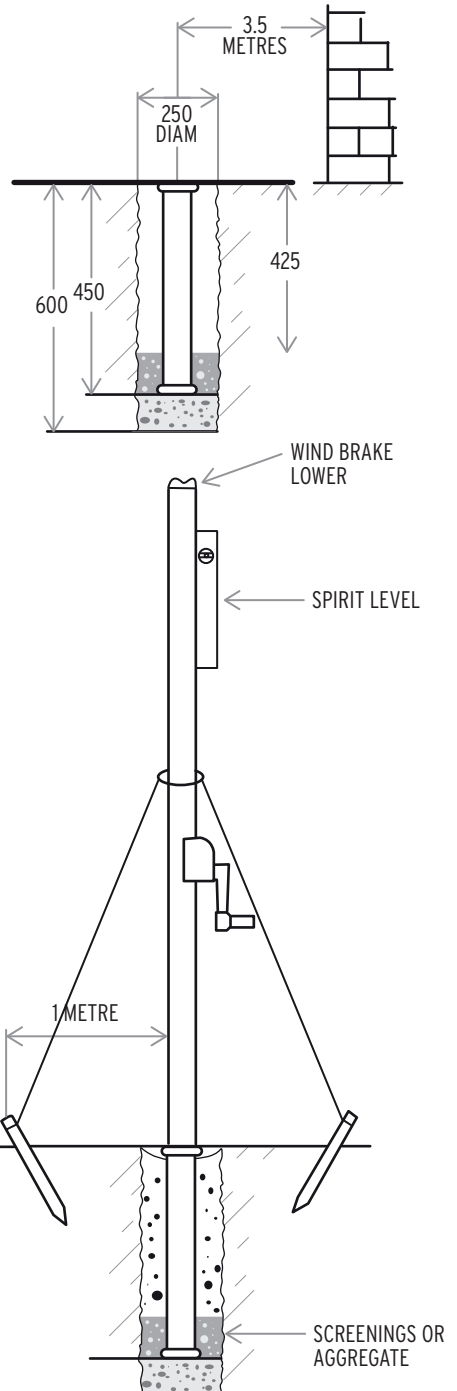

Assembling the Clothesline

1. Remove the cord and stabilising stakes.
2. Gently slide the hoist tube assembly into the main tube assembly until the units engage together. The tube assemblies are engaged when both the upper and lower wind brake face meet.
3. Cut the rubber bands holding the lines to the arms.
4. Slide the yellow ring upwards, this allows arms to be folded out to horizontal position where the dual latches will lock the arms in place.

5. Turn the handle clockwise to move the hoist up.
6. To activate the wind brake, turn the handle anti-clockwise until the two serrated plastic faces meet.

Please Note: There is a safety clutch within the gear box. When the clothesline is in the maximum lowest or highest positions the handle will rotate freely (clicking sound), which prevents damage to the gear box.

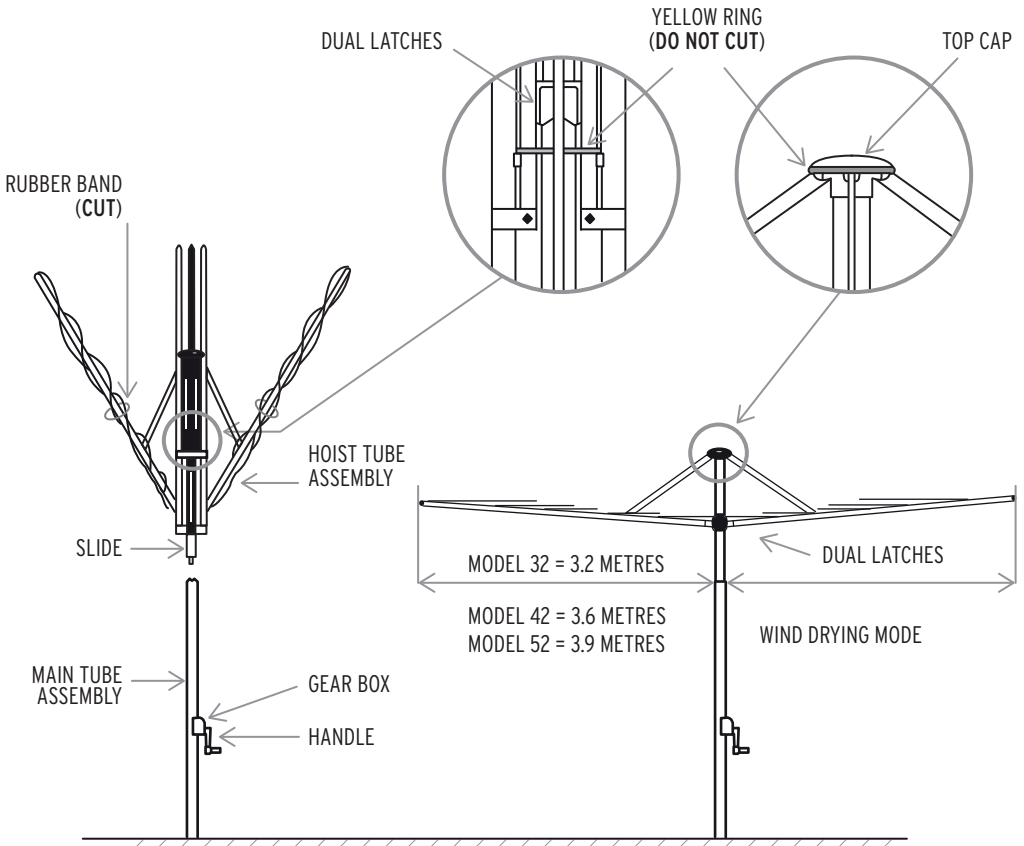

Adjusting Clothesline Height

The ideal height of the clothesline should be approximately 50mm from the users head height to the underside of the horizontal arms (with the wind brake engaged).

The clothesline can be adjusted to three levels of adjustment via the ground socket:

1 – Highest

2 – Medium

3 – Lowest

Your clothesline is supplied with the ground socket in the lowest position 3. To adjust into higher positions, lift the support ring from the ground socket, lift the clothesline and twist into position 1 or 2. Each position will increase your clothesline height by 75mm. With the clothesline at the required height replace the support ring into the ground socket.

To Fold Away Clothesline

1. Wind down the clothesline to the wind brake position.
2. Press the dual latches inward and slide downwards until all 4 arms are in a vertical position and are secured in the slots located in the top cap.
3. Lift the support ring from the ground socket and lift out the clothesline.
4. Insert the ground socket cap for protection while the clothesline is removed.

Helpful Hints

- a) Engage the wind brake mechanism while pegging and unpegging washing. By pulling on the horizontal arm the clothesline will rotate to the next loading position.
- b) Hang washing starting from the inside line with small garments.
- c) Distribute the weight of washing evenly on each line around the four quadrants.
- d) After hanging the washing it is important to wind the line up off the wind brake for spin air drying.
- e) Located at the end of each horizontal arm is a clothesline hanger loop.

Important

Please ensure your clothesline is not used as a playing item by children swinging on lines and main arms. Any damage from misuse will void the warranty.

Product Warranty

If any part of this clothesline fails to operate correctly due to faulty workmanship or defective material Dayton Tooling will repair or replace free of cost within 10 years from the date of purchase. (Receipt of purchase required). The PVC line cord is covered by a 2 year warranty from the date of purchase. Any evidence of misuse or incorrect adjustment will void the warranty.

Manufactured by Dayton Tooling Pty Ltd
77-81 Gower Street, Preston Victoria 3072
T (03) 9470 1755 F (03) 9470 5381

www.daytek.com.au